

### Silicon NPN High Voltage Switching Transistor

#### Features

- Simple-sWitch-Off Transistor (SWOT)
- HIGH SPEED technology
- Planarpassivation
- 100 kHz switching rate
- Very low switching losses
- Very low dynamic saturation
- Very low operating temperature
- Optimized RBSOA
- High reverse voltage

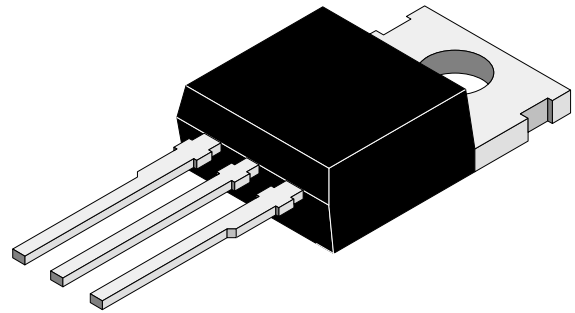

95 9630

#### Applications

Electronic lamp ballast circuits  
Switch-mode power supplies

#### Absolute Maximum Ratings

$T_{\text{case}} = 25^{\circ}\text{C}$ , unless otherwise specified

Parameter	Test Conditions	Type	Symbol	Value	Unit
Collector-emitter voltage		BUF640	$V_{\text{CEO}}$	400	V
		BUF640A	$V_{\text{CEO}}$	450	V
		BUF640	$V_{\text{CES}}$	850	V
		BUF640A	$V_{\text{CES}}$	1000	V
Emitter-base voltage			$V_{\text{EBO}}$	9	V
Collector current			$I_{\text{C}}$	6	A
Collector peak current			$I_{\text{CM}}$	9	A
Base current			$I_{\text{B}}$	3	A
Base peak current			$I_{\text{BM}}$	5	A
Total power dissipation	$T_{\text{case}} = 25^{\circ}\text{C}$		$P_{\text{tot}}$	70	W
Junction temperature			$T_{\text{j}}$	150	$^{\circ}\text{C}$
Storage temperature range			$T_{\text{stg}}$	-65 to +150	$^{\circ}\text{C}$

### Maximum Thermal Resistance

$T_{\text{case}} = 25^{\circ}\text{C}$ , unless otherwise specified

Parameter	Test Conditions	Symbol	Value	Unit
Junction case		$R_{\text{thJC}}$	1.78	K/W

### Electrical Characteristics

$T_{\text{case}} = 25^{\circ}\text{C}$ , unless otherwise specified

Parameter	Test Conditions	Type	Symbol	Min	Typ	Max	Unit
Collector cut-off current	$V_{\text{CE}} = 850 \text{ V}$	BUF640	$I_{\text{CES}}$			100	$\mu\text{A}$
	$V_{\text{CE}} = 1000 \text{ V}$	BUF640A	$I_{\text{CES}}$			100	$\mu\text{A}$
	$V_{\text{CE}} = 850 \text{ V}; T_{\text{case}} = 150^{\circ}\text{C}$	BUF640	$I_{\text{CES}}$			0.5	mA
	$V_{\text{CE}} = 1000 \text{ V}; T_{\text{case}} = 150^{\circ}\text{C}$	BUF640A	$I_{\text{CES}}$			0.5	mA
Collector-emitter breakdown voltage (figure 1)	$I_{\text{C}} = 500 \text{ mA}; L = 125 \text{ mH}; I_{\text{measure}} = 100 \text{ mA}$	BUF640	$V_{(\text{BR})\text{CEO}}$	400			V
		BUF640A	$V_{(\text{BR})\text{CEO}}$	450			V
Emitter-base breakdown voltage	$I_{\text{E}} = 1 \text{ mA}$		$V_{(\text{BR})\text{EBO}}$	9			V
Collector-emitter saturation voltage	$I_{\text{C}} = 1 \text{ A}; I_{\text{B}} = 0.1 \text{ A}$		$V_{\text{CEsat}}$			0.5	V
	$I_{\text{C}} = 2.5 \text{ A}; I_{\text{B}} = 0.5 \text{ A}$		$V_{\text{CEsat}}$			0.75	V
Base-emitter saturation voltage	$I_{\text{C}} = 1 \text{ A}; I_{\text{B}} = 0.1 \text{ A}$		$V_{\text{BEsat}}$			1.1	V
	$I_{\text{C}} = 2.5 \text{ A}; I_{\text{B}} = 0.5 \text{ A}$		$V_{\text{BEsat}}$			1.2	V
DC forward current transfer ratio	$V_{\text{CE}} = 2 \text{ V}; I_{\text{C}} = 0.1 \text{ A}$		$h_{\text{FE}}$	15			
	$V_{\text{CE}} = 2 \text{ V}; I_{\text{C}} = 1 \text{ A}$		$h_{\text{FE}}$	15			
	$V_{\text{CE}} = 2 \text{ V}; I_{\text{C}} = 2.5 \text{ A}$		$h_{\text{FE}}$	8			
	$V_{\text{CE}} = 5 \text{ V}; I_{\text{C}} = 5 \text{ A}$		$h_{\text{FE}}$	4			
Collector-emitter working voltage	$V_{\text{S}} = 50 \text{ V}; L = 1 \text{ mH}; I_{\text{C}} = 2.5 \text{ A}; I_{\text{B1}} = 0.5 \text{ A}; -I_{\text{B2}} = 0.5 \text{ A}; -V_{\text{BE(off)}} = 5 \text{ V}$	BUF640A	$V_{\text{CEW}}$	550			V

## Switching Characteristics

$T_{\text{case}} = 25^{\circ}\text{C}$ , unless otherwise specified

Parameter	Test Conditions	Symbol	Min	Typ	Max	Unit
Resistive load (figure 2)						
Turn on time	$I_C = 2.5 \text{ A}; I_{B1} = 0.5 \text{ A}; -V_{BB} = 0;$ $R_{BB} = 0.6 \Omega$	$t_{\text{on}}$			0.7	$\mu\text{s}$
Storage time		$t_s$			1.8	$\mu\text{s}$
Fall time		$t_f$			0.4	$\mu\text{s}$
Turn on time	$I_C = 2.5 \text{ A}; I_{B1} = 0.5 \text{ A}; -I_{B2} = 1.25 \text{ A};$ $V_S = 150 \text{ V}$	$t_{\text{on}}$			0.7	$\mu\text{s}$
Storage time		$t_s$			1.8	$\mu\text{s}$
Fall time		$t_f$			0.4	$\mu\text{s}$
Inductive load (figure 3)						
Storage time	$I_C = 2.5 \text{ A}; I_{B1} = 0.5 \text{ A}; -V_{BE(\text{off})} = 0;$ $R_{BB} = 0.6 \Omega;$ $V_{\text{clamp}} = 300 \text{ V}; L = 200 \mu\text{H}$	$t_s$		1.6	2.2	$\mu\text{s}$
Fall time		$t_f$		0.13	0.2	$\mu\text{s}$
Cross over time		$t_c$		0.25	0.4	$\mu\text{s}$
Storage time	$I_C = 2.5 \text{ A}; I_{B1} = 0.5 \text{ A}; -I_{B2} = 1.25 \text{ A}$ $V_{\text{clamp}} = 300 \text{ V}; L = 200 \mu\text{H};$	$t_s$		1.7	2.5	$\mu\text{s}$
Fall time		$t_f$		0.15	0.25	$\mu\text{s}$
Cross over time		$t_c$		0.3	0.5	$\mu\text{s}$

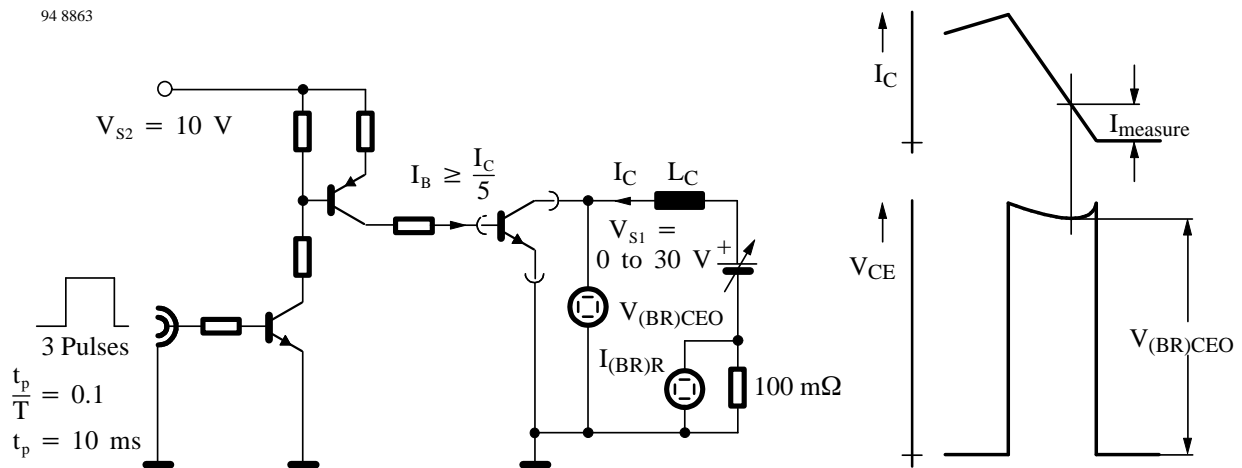

94 8852

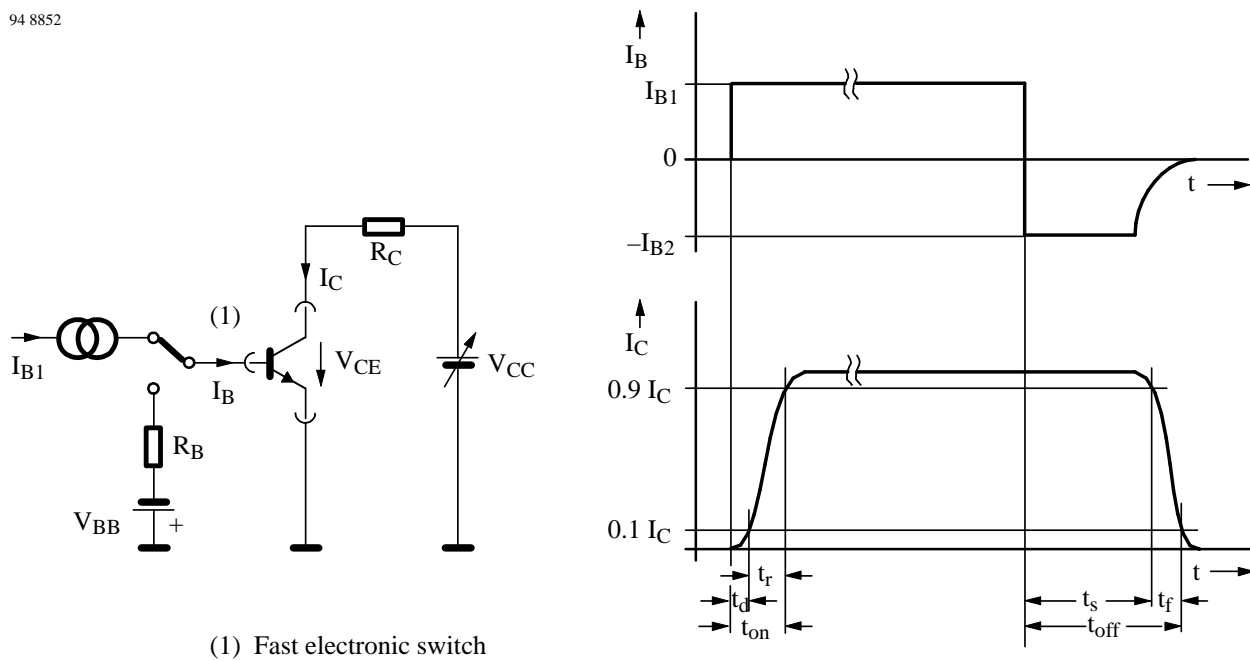

Figure 2. Test circuit for switching characteristics – resistive load

94 8853

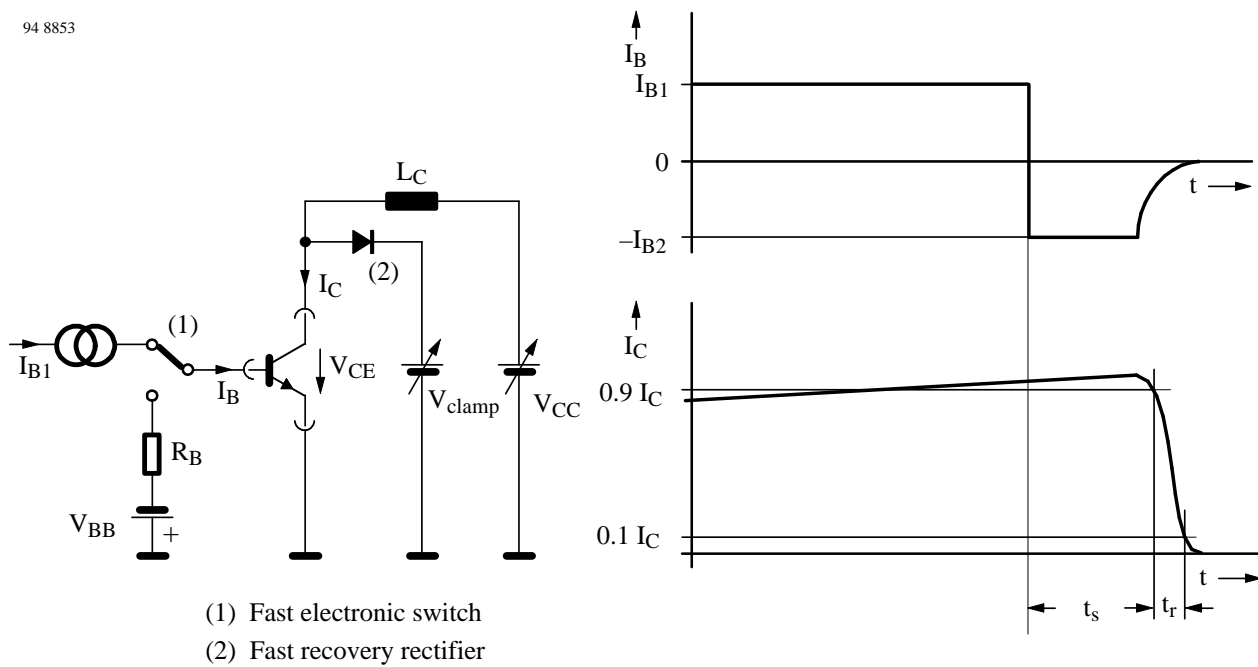

Figure 3. Test circuit for switching characteristics – inductive load

## Typical Characteristics ( $T_{case} = 25^{\circ}C$ unless otherwise specified)

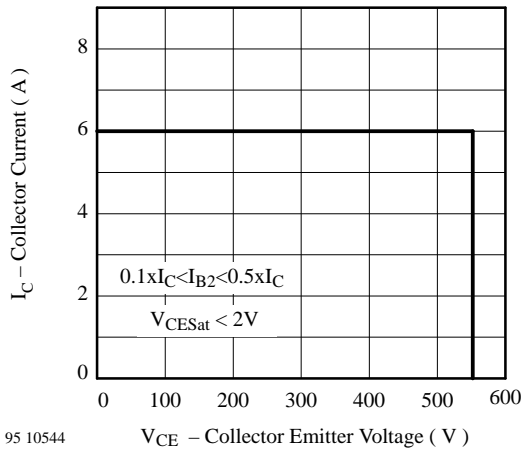

Figure 4.  $V_{CEW}$  - Diagram

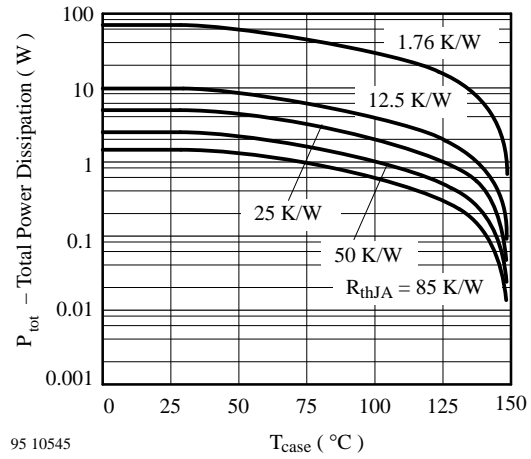

Figure 7.  $P_{tot}$  vs.  $T_{case}$

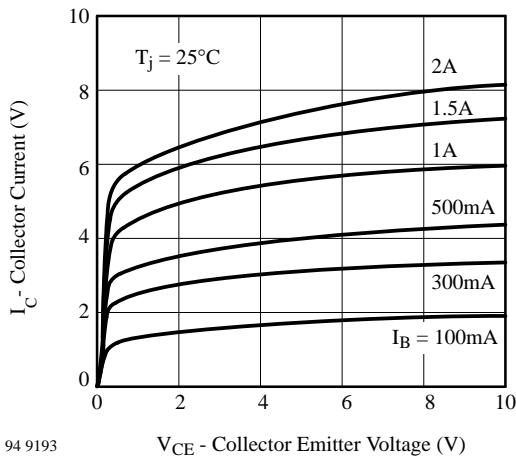

Figure 5.  $I_C$  vs.  $V_{CE}$

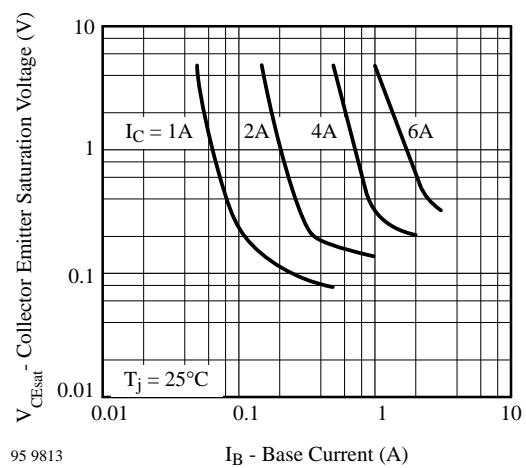

Figure 8.  $V_{CEsat}$  vs.  $I_B$

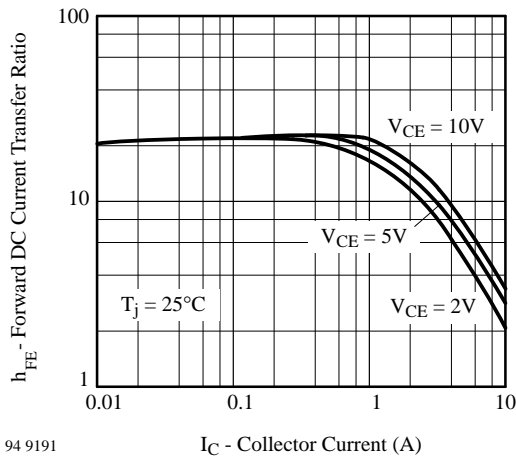

Figure 6.  $h_{FE}$  vs.  $I_C$

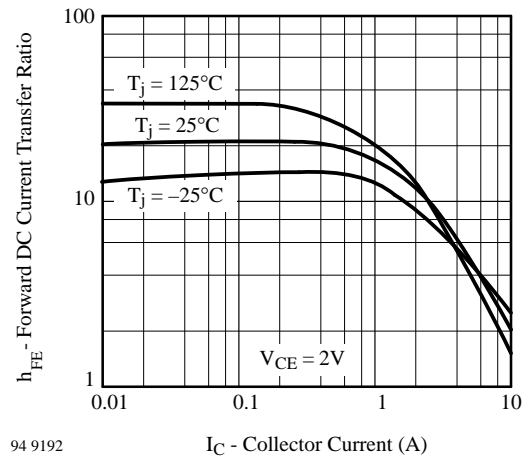

Figure 9.  $h_{FE}$  vs.  $I_C$

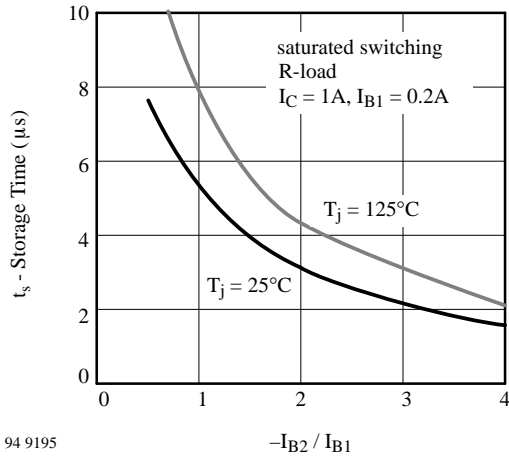

Figure 10.  $t_s$  vs.  $-I_{B2}/I_{B1}$

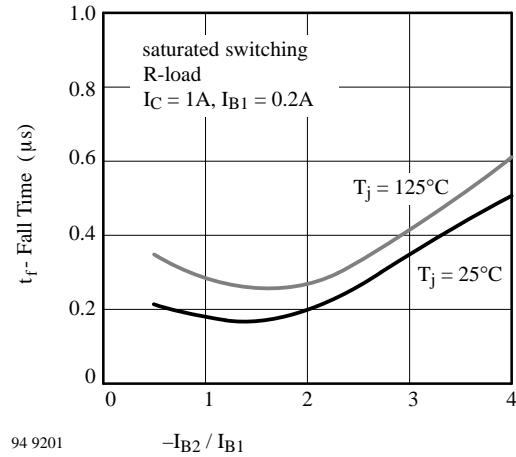

Figure 13.  $t_f$  vs.  $-I_{B2}/I_{B1}$

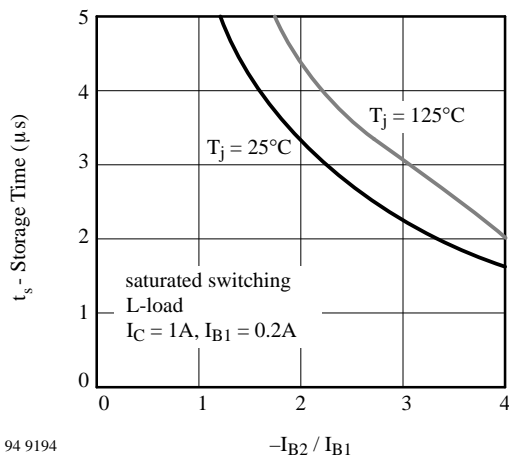

Figure 11.  $t_s$  vs.  $-I_{B2}/I_{B1}$

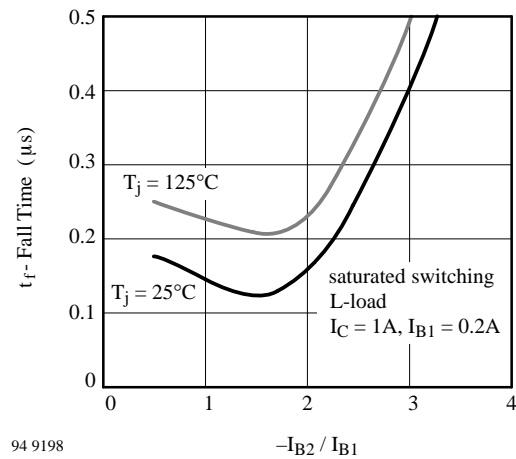

Figure 14.  $t_f$  vs.  $-I_{B2}/I_{B1}$

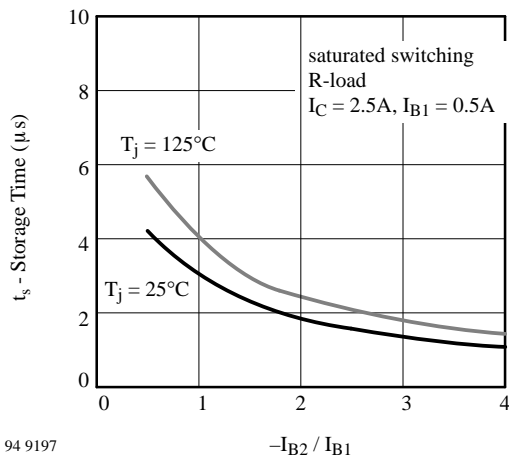

Figure 12.  $t_s$  vs.  $-I_{B2}/I_{B1}$

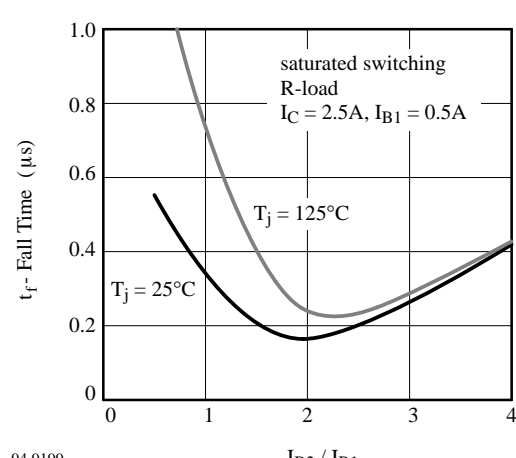

Figure 15.  $t_f$  vs.  $-I_{B2}/I_{B1}$

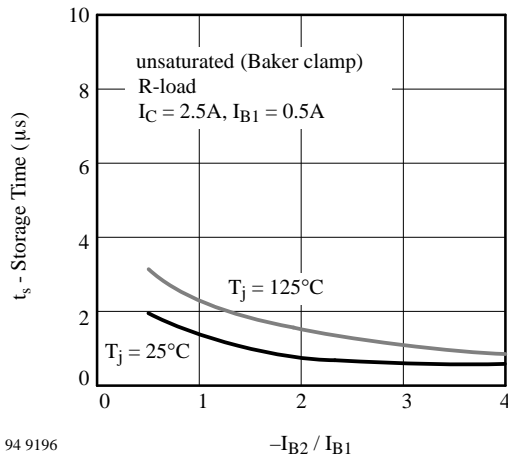

Figure 16.  $t_s$  vs.  $-I_{B2}/I_{B1}$

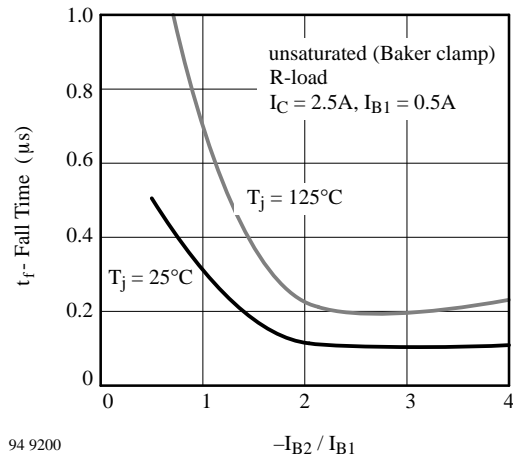
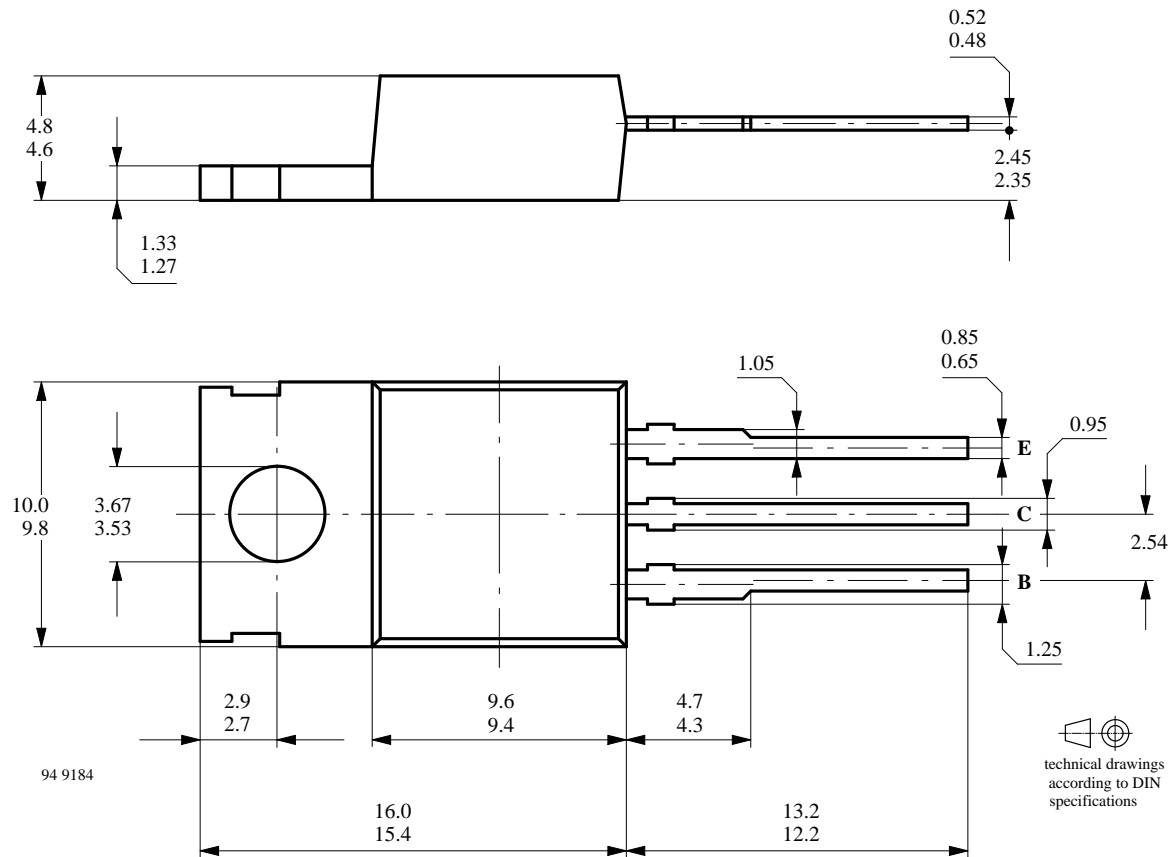

Figure 17.  $t_f$  vs.  $-I_{B2}/I_{B1}$

### Dimensions in mm



Collector connected with metallic surface

Standard Plastic Case  
14A 3 DIN 41 869  
JEDEC TO 220

## Ozone Depleting Substances Policy Statement

It is the policy of **TEMIC TELEFUNKEN microelectronic GmbH** to

1. Meet all present and future national and international statutory requirements.
2. Regularly and continuously improve the performance of our products, processes, distribution and operating systems with respect to their impact on the health and safety of our employees and the public, as well as their impact on the environment.

It is particular concern to control or eliminate releases of those substances into the atmosphere which are known as ozone depleting substances (ODSs).

The Montreal Protocol (1987) and its London Amendments (1990) intend to severely restrict the use of ODSs and forbid their use within the next ten years. Various national and international initiatives are pressing for an earlier ban on these substances.

**TEMIC TELEFUNKEN microelectronic GmbH** semiconductor division has been able to use its policy of continuous improvements to eliminate the use of ODSs listed in the following documents.

1. Annex A, B and list of transitional substances of the Montreal Protocol and the London Amendments respectively
2. Class I and II ozone depleting substances in the Clean Air Act Amendments of 1990 by the Environmental Protection Agency (EPA) in the USA
3. Council Decision 88/540/EEC and 91/690/EEC Annex A, B and C (transitional substances) respectively.

**TEMIC** can certify that our semiconductors are not manufactured with ozone depleting substances and do not contain such substances.

**We reserve the right to make changes to improve technical design and may do so without further notice.**

Parameters can vary in different applications. All operating parameters must be validated for each customer application by the customer. Should the buyer use TEMIC products for any unintended or unauthorized application, the buyer shall indemnify TEMIC against all claims, costs, damages, and expenses, arising out of, directly or indirectly, any claim of personal damage, injury or death associated with such unintended or unauthorized use.

TEMIC TELEFUNKEN microelectronic GmbH, P.O.B. 3535, D-74025 Heilbronn, Germany  
Telephone: 49 (0)7131 67 2831, Fax number: 49 (0)7131 67 2423